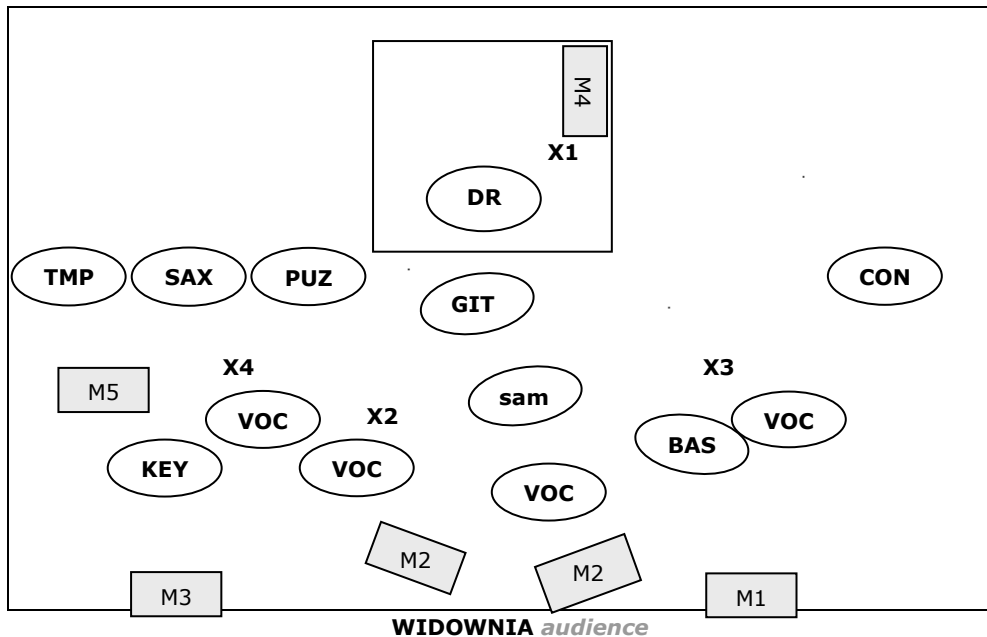

MENEDŻER PROJEKTU *PROJECT MANAGER*

Imię i nazwisko <i>name</i>	
Telefon biurowy <i>office phone number</i>	
Plus	+48 663 056 798
Email	Jarekpacanek@poczta.fm

PLAN SCENY *STAGE PLAN*

4 VOC, GIT, BAS,
2 KEY, SAX,
TRUMPET, PUZON
DR, CONGAS

instrumenty i wokale *instruments and vocals*

M1-M5

monitory odsłuchowe, niezależne linie odsłuchowe *stage monitors, separate stage monitor lines*

X1 - X5

liczba i lokalizacja źródeł zasilania *number and placement of power sources*

INPUT LISTA *Channel list*

FOH	MON	Instrument	Mic/D.I.	FOH insert
1.	BD	BD	BETA52/D112	GATE
2.		SD	SM57	GATE
3.		OL	SM81/AKG C1000S	
4.		SD	SM57	GATE
5.		OR	SM81/AKG C1000S	
6.		HH	SM81/AKG C1000S	
7.		HI TOM	E604	GATE
8.		LO TOM	E604	GATE
9.	BASS_	BASS_	DI BOX	COMP
10.	KEY1 L	KEY 1 L	DI BOX	
11.	KEY1 R	KEY 1 R	DI BOX	
12.	E.GUIT	E.GUIT_	SM57	
13.	KEY 2	KEY 2	DI BOX	
14.	VOX	VOX 1	SM58 ULX	COMP
15.	VOX	VOX 2	SM58 ULX	COMP
16.	VOX	VOX 3	SM58 ULX	COMP
17.	VOX	VOX 4	SM58 ULX	COMP
18.	SAX	SAX	SM57	COMP
19.	TRUMPET	TRUMPET	SM57	COMP
20.	PUZON	PUZON	SM57	COMP
21.	CONGA	CONGA	SM57	GATE
22.	CONGA	CONGA	SM57	GATE

NAGŁOŚNIENIE FRONTOWE *FOH SECTION*

Mikser <i>Mixing console</i>	PROFESIONAL <i>PROFI!</i>
Mikser parametry <i>Mixing console details</i>	24 IN, 4 grupy stereo; w 2 grupach stereo zainstrowane 4 compressorry
Peryferia	5 bramek, 8 compressorów (np.dbx, BEHRINGER!), Yamaha SPX 990, Lexicon PCM 90, Lexicon MPX 500, t.c.electronic M-One
Głośniki frontowe <i>FOH loudspeakers</i>	3kW/str,

DYR

itory sceniczne *Stage monitors*
lizator dźwięku *Sound mixer*

5 linie (stół monitorowy)

AGI COMMENTS